



Feature

- Pure aluminum heatsink
- Nichia 757G
- Meanwell HBG-160
- Up to 115-135lm/w
- 5 years warranty

Certificate&Report

UL / DLC / TUV / SAA / PSE
LM-80 / LM-79 / IES

General information

Part No.:	BT-TH150W
Power:	150W±5%
Input Voltage:	Ac90-305V
Power Factor:	>0.95
CCT:	3000/4000/5000/5700K
CRI:	Ra80
Lumen:	17250lm±5%
Beam angle:	120°
Dimmable:	0-10V
IP grade:	IP65
Lifespan:	40,000H at 50°C ambient temperature
Working Temperature:	-40 - 50°C
Installing method:	Hanging hook / Adjustable bracket / NPT
Material:	Aluminum + PC
Weight:	4.5KG
Accessory:	Reflector, dust-proof shield
Remarks:	1. Available with DALI dimming 2. Available with Sensor – Occupancy and Daylight

Dimensions

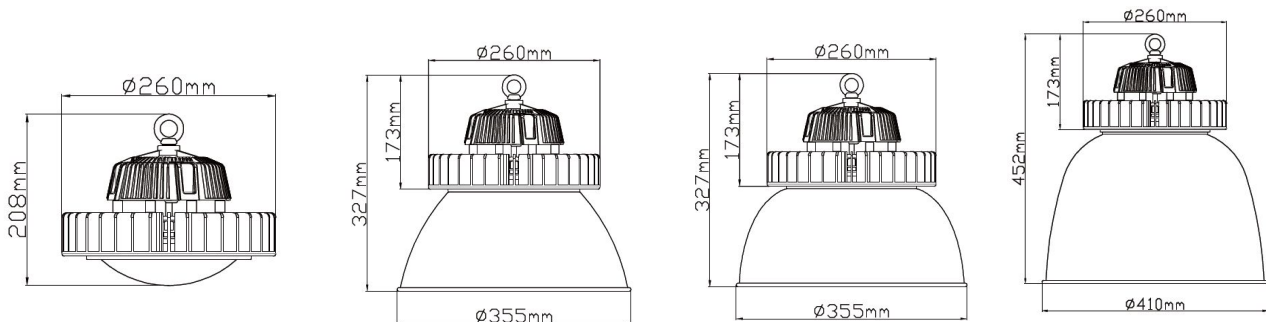

No reflector
120degree

Aluminum reflector
60degree

Aluminum reflector
90degree

PC reflector
70degree